



(19) **United States**

(12) **Patent Application Publication** (10) **Pub. No.: US 2005/0212415 A1**

Jung et al.

(43) **Pub. Date:**

Sep. 29, 2005

(54) **ORGANIC ELECTRO-LUMINESCENCE DISPLAY DEVICE AND METHOD OF FABRICATING THE SAME**

Publication Classification

(51) **Int. Cl.⁷** **H05B 33/00; H01J 1/62; H01J 63/04**
(52) **U.S. Cl.** **313/504; 313/505**

(75) **Inventors:** **Young Ro Jung**, Gyeongsangbuk-do (KR); **Jae Hyoung Ju**, Daegu (KR)

Correspondence Address:
BIRCH STEWART KOLASCH & BIRCH
PO BOX 747
FALLS CHURCH, VA 22040-0747 (US)

(57) **ABSTRACT**

This invention relates to an organic electro-luminescence device and a method of fabricating the same that is capable of reducing an inverse taper of a bus electrode.

(73) **Assignee:** **LG Electronics Inc.**

(21) **Appl. No.:** **11/084,791**

(22) **Filed:** **Mar. 21, 2005**

(30) **Foreign Application Priority Data**

Mar. 23, 2004 (KR)..... P2004-19684

An organic electro-luminescence display device comprises: an anode electrode including a transparent electrode and a bus electrode; a cathode electrode crossing the anode electrode; and an organic layer located at a cross both the anode electrode and the cathode electrode, wherein the bus electrode has an inclination angle of 30° to 70°.

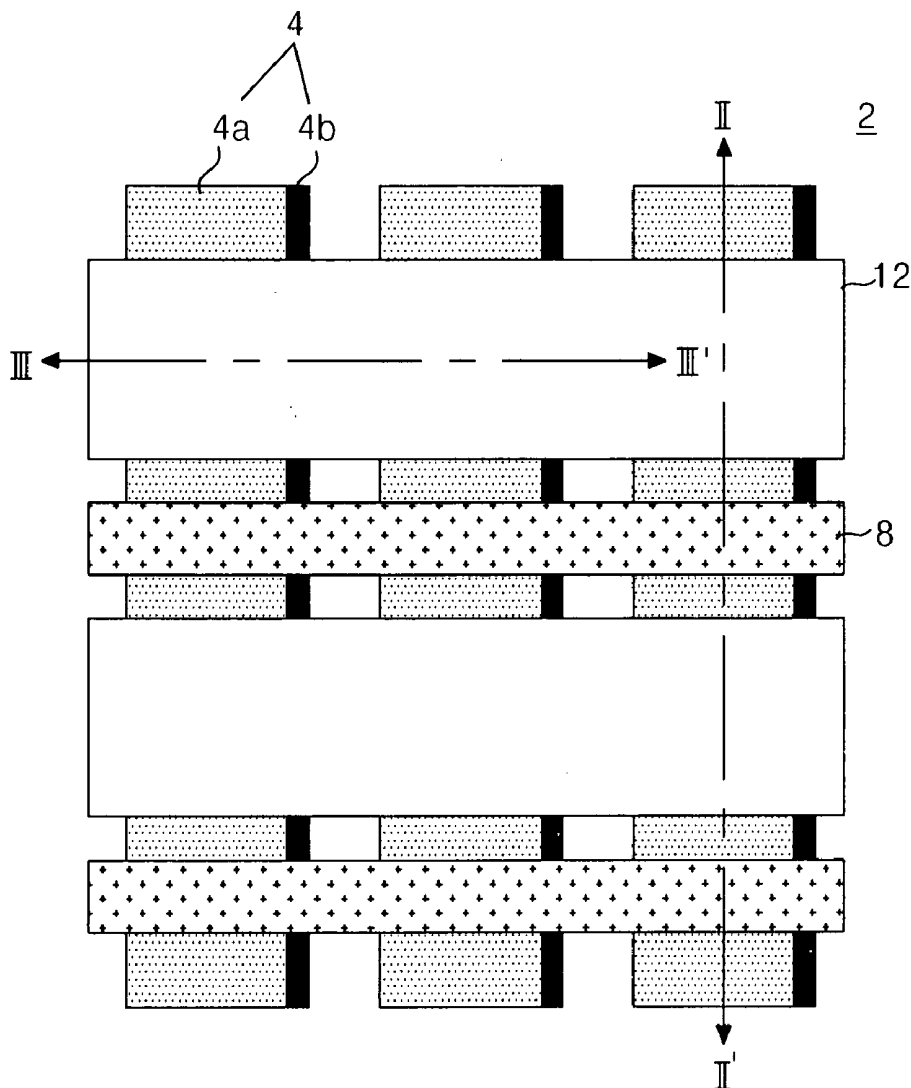

FIG. 1
RELATED ART

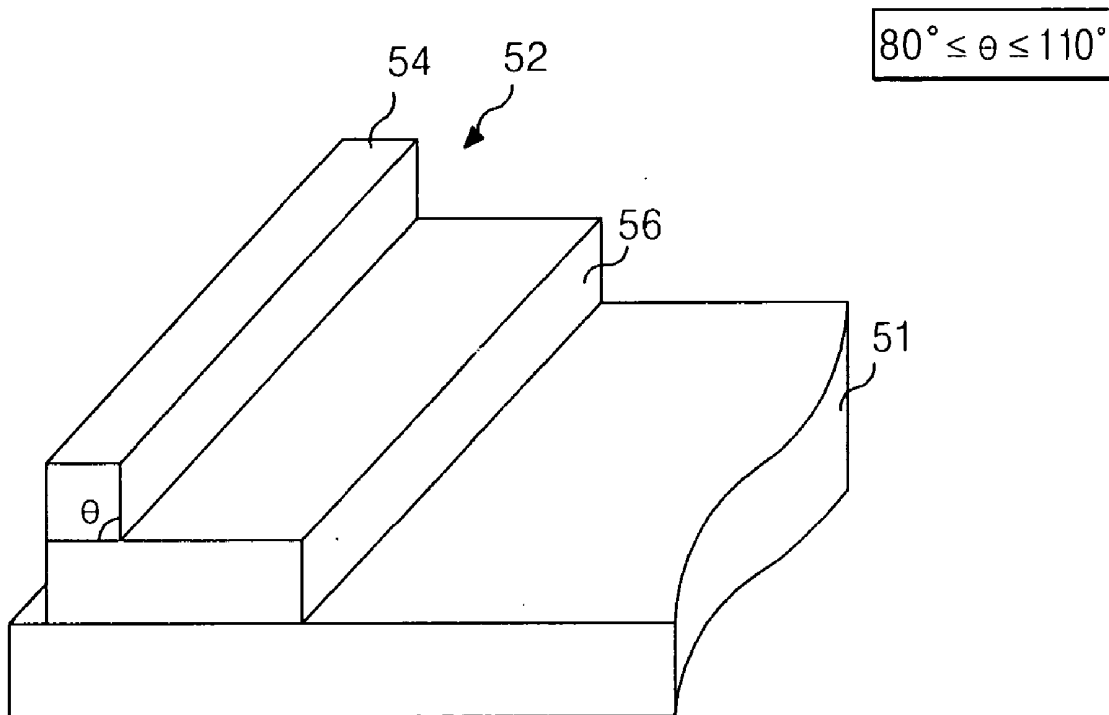

FIG. 2
RELATED ART

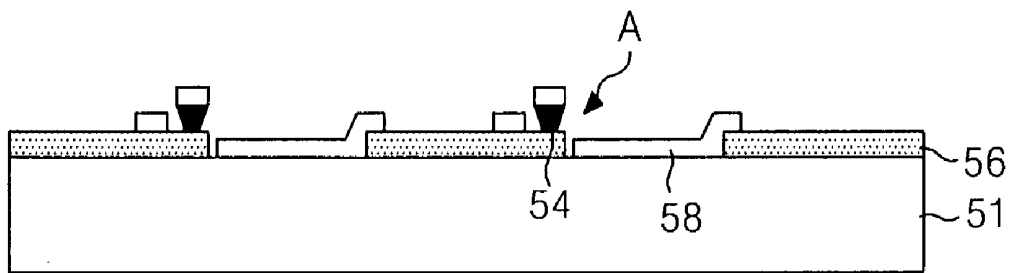

FIG. 3

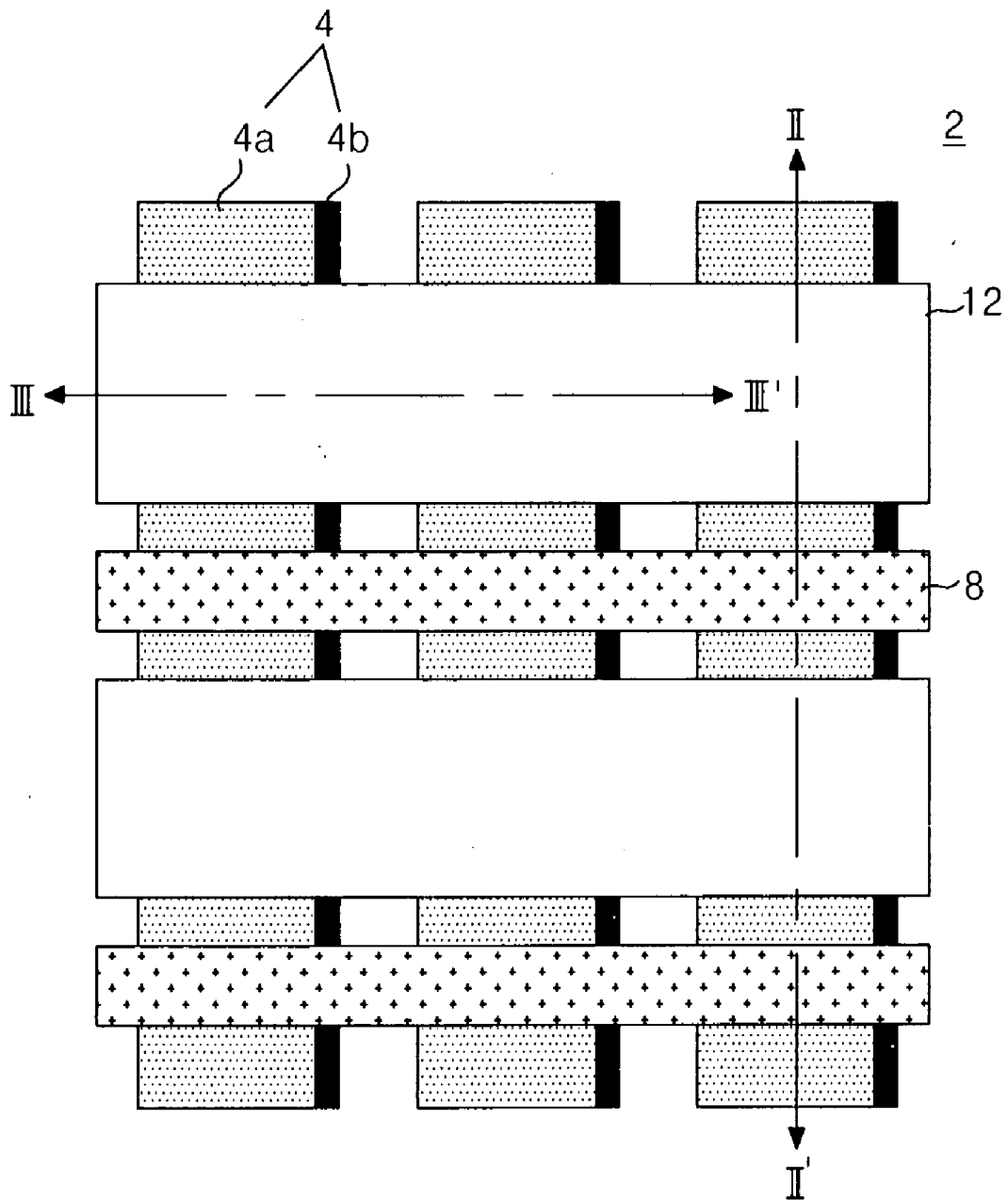

FIG. 4

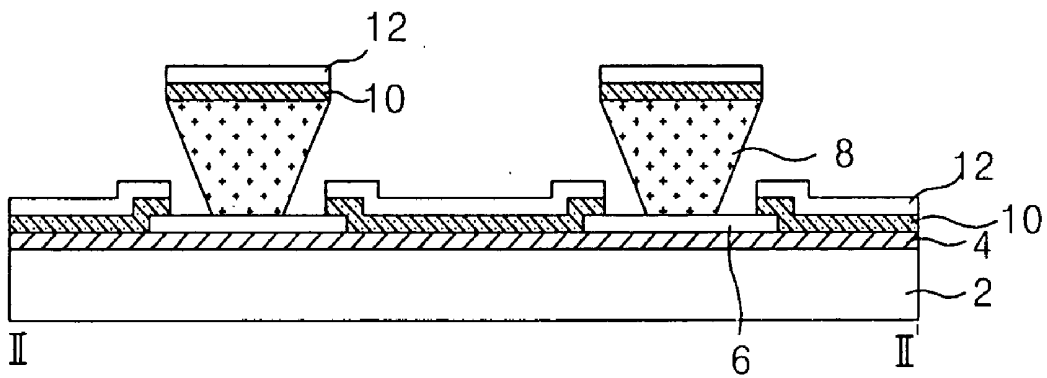

FIG. 5

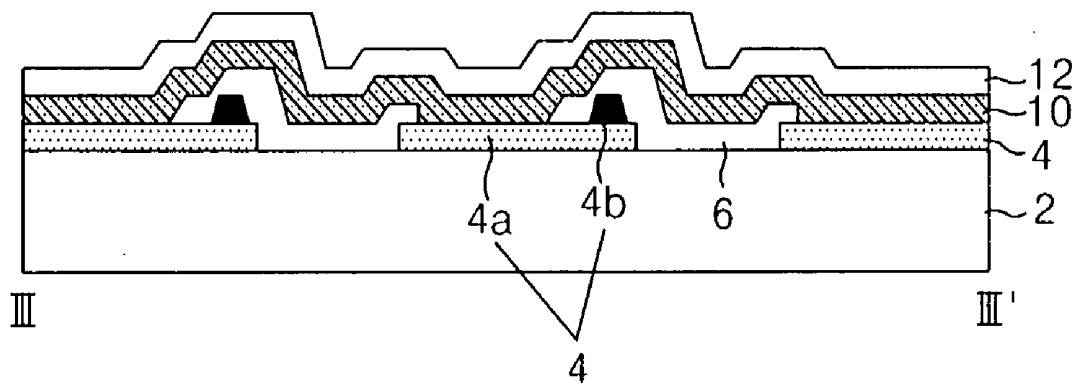

FIG. 6A

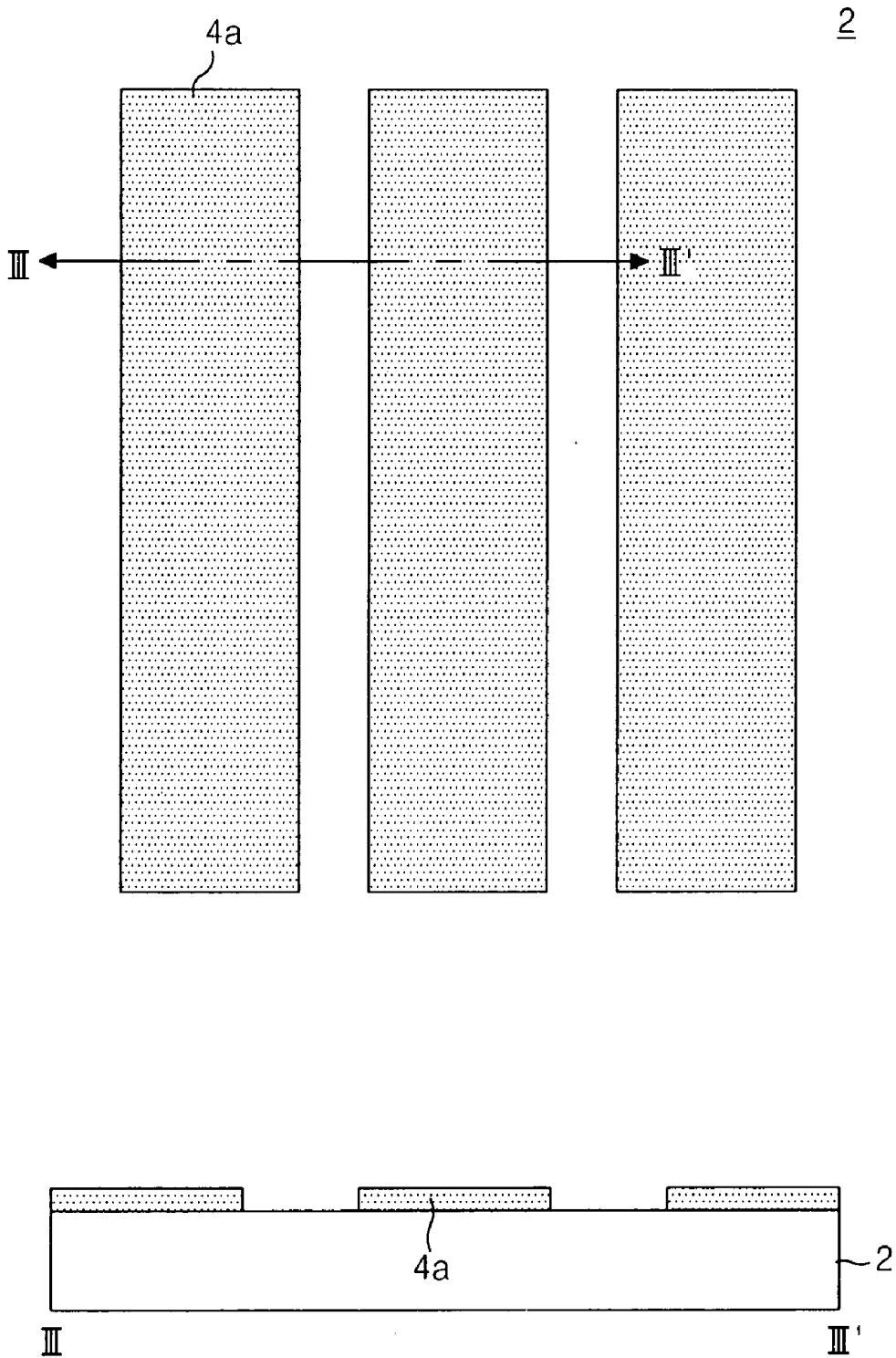

FIG. 6B

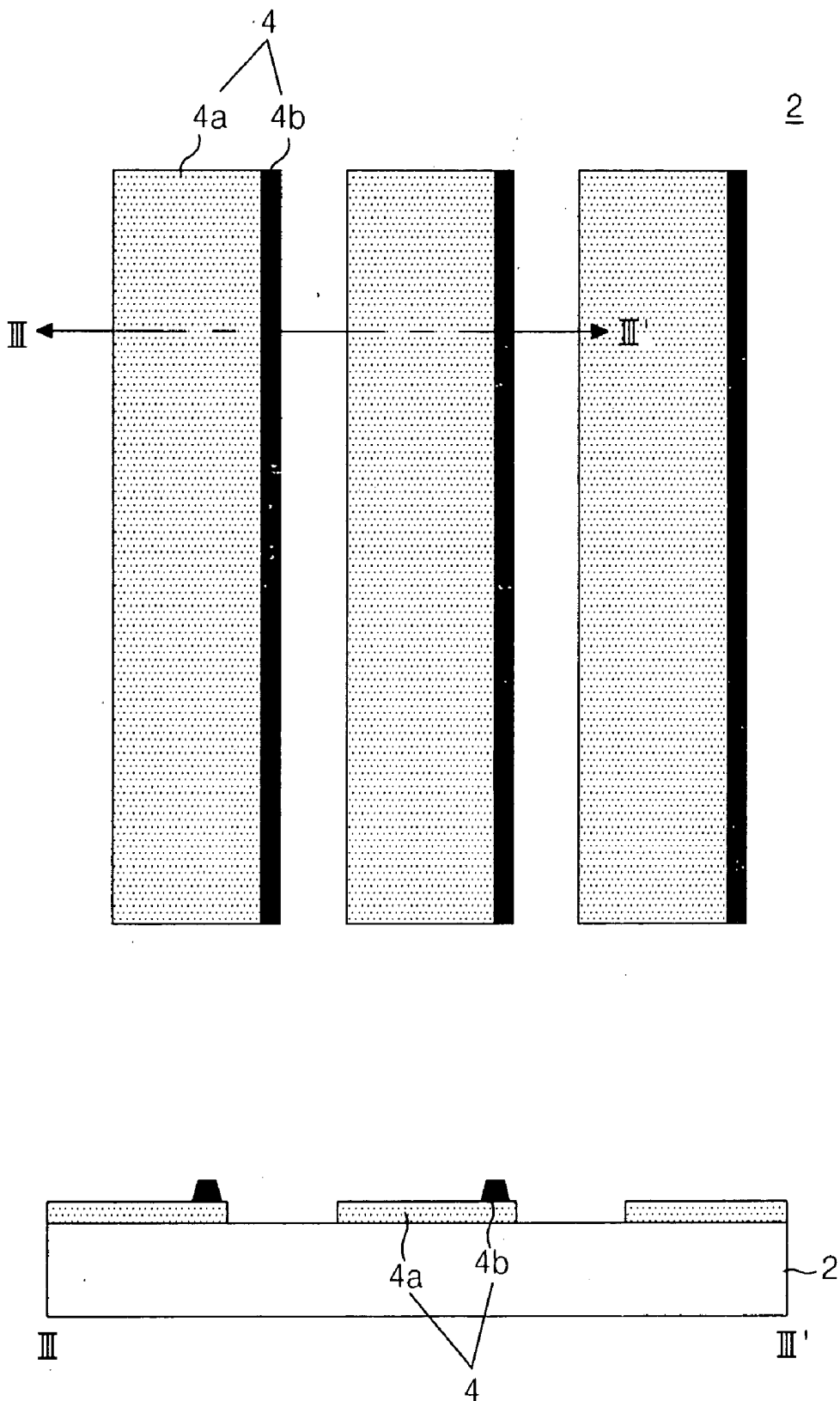

FIG. 6C

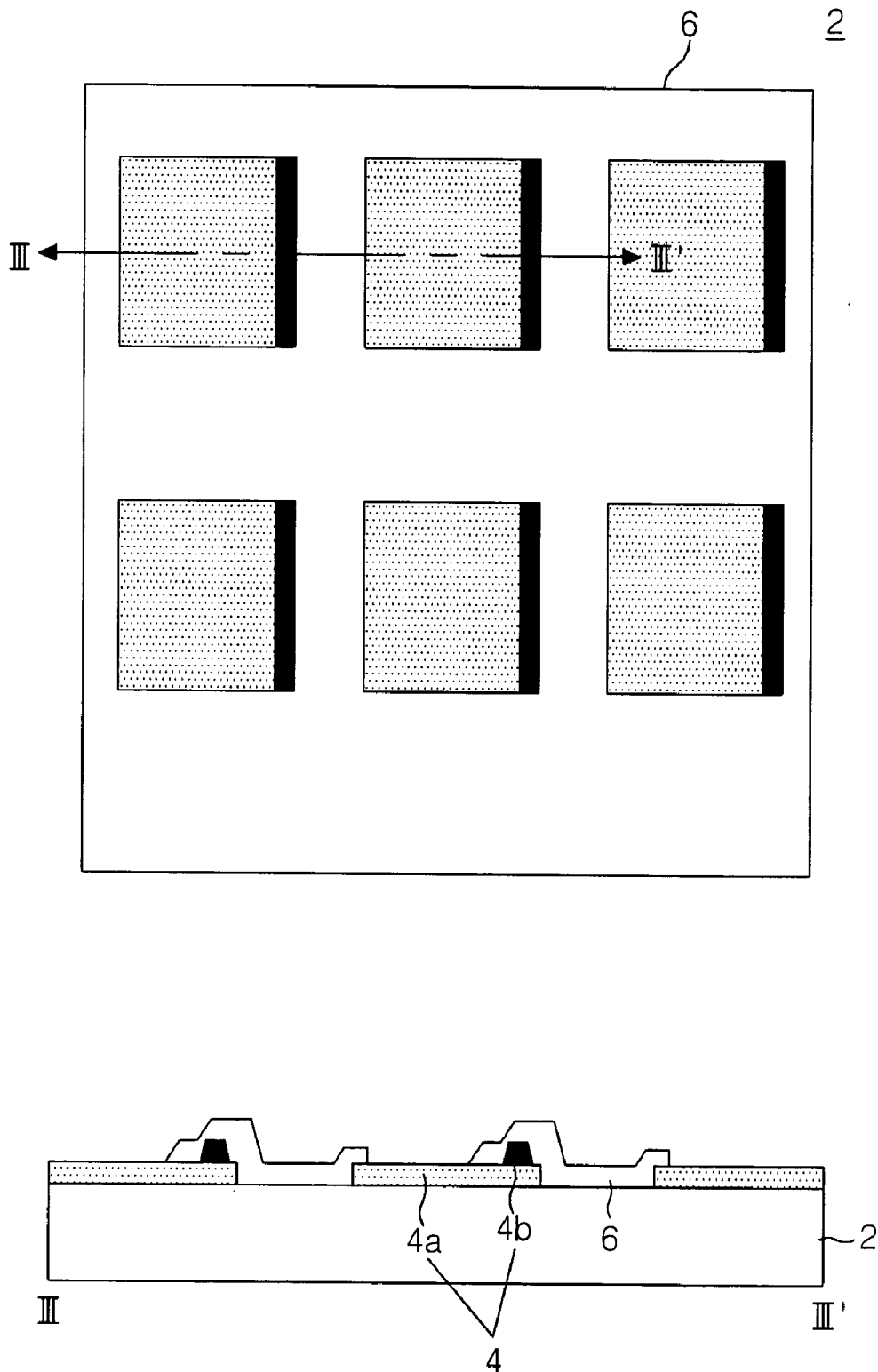

FIG. 6D

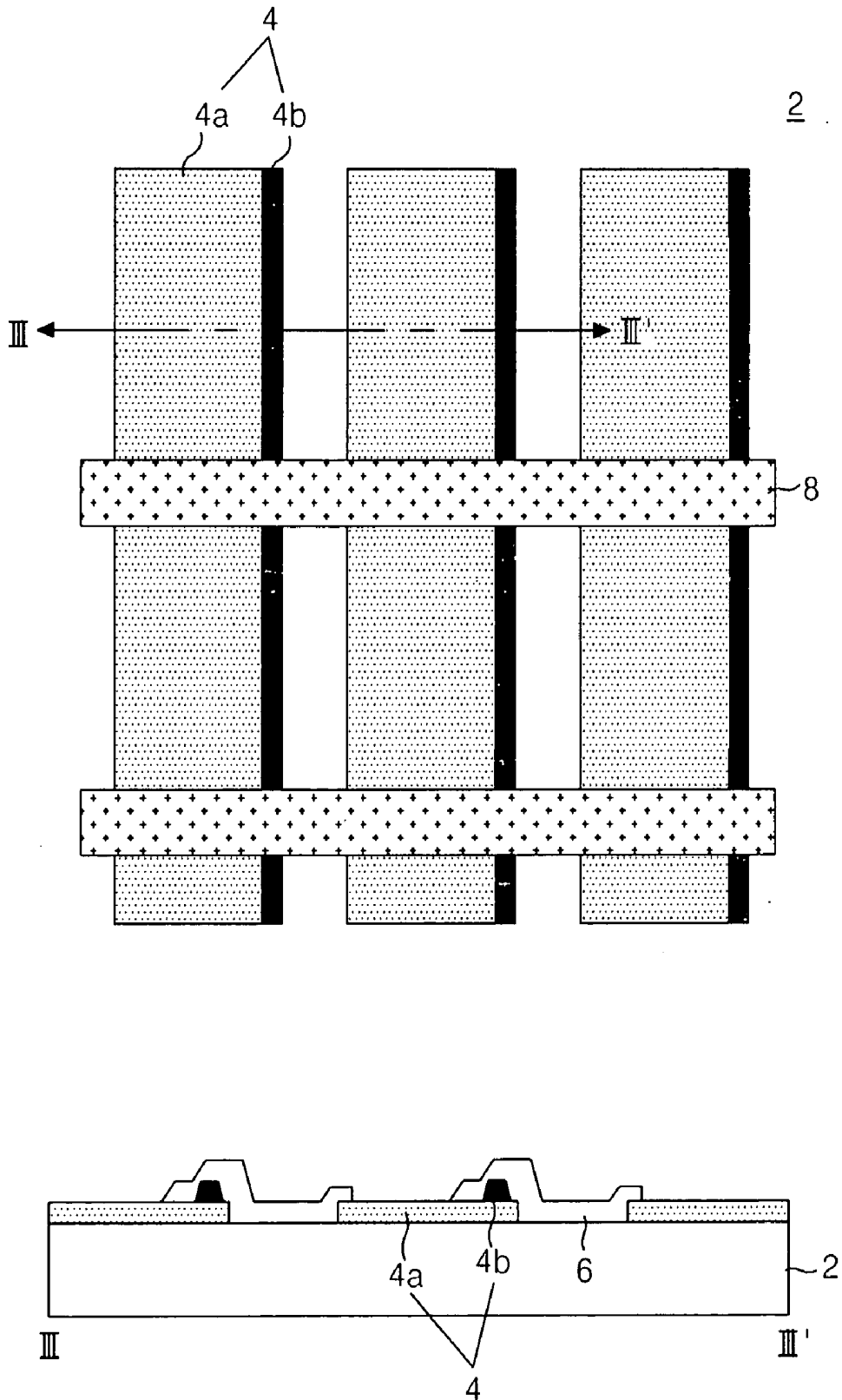

FIG. 6E

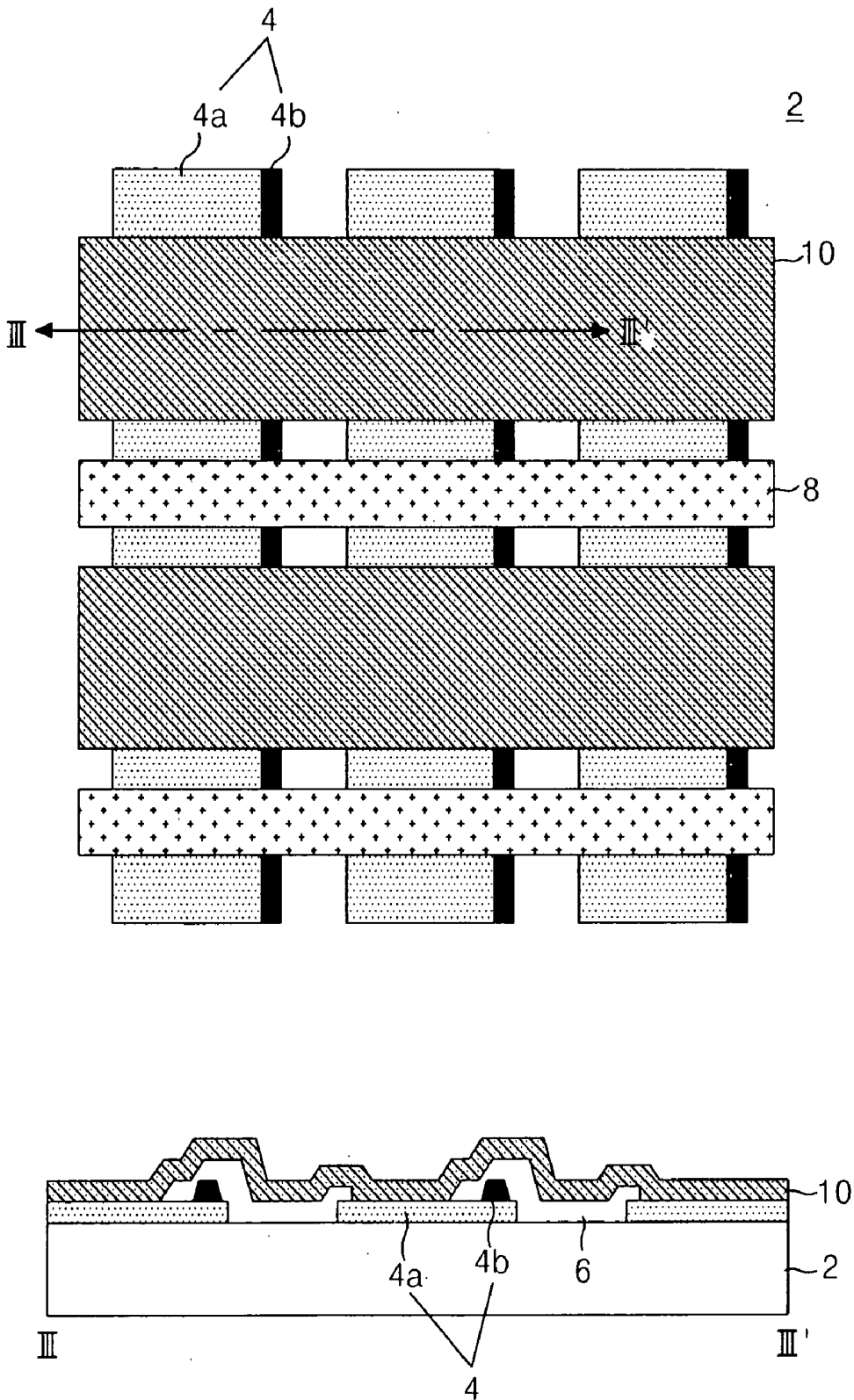

FIG. 6F

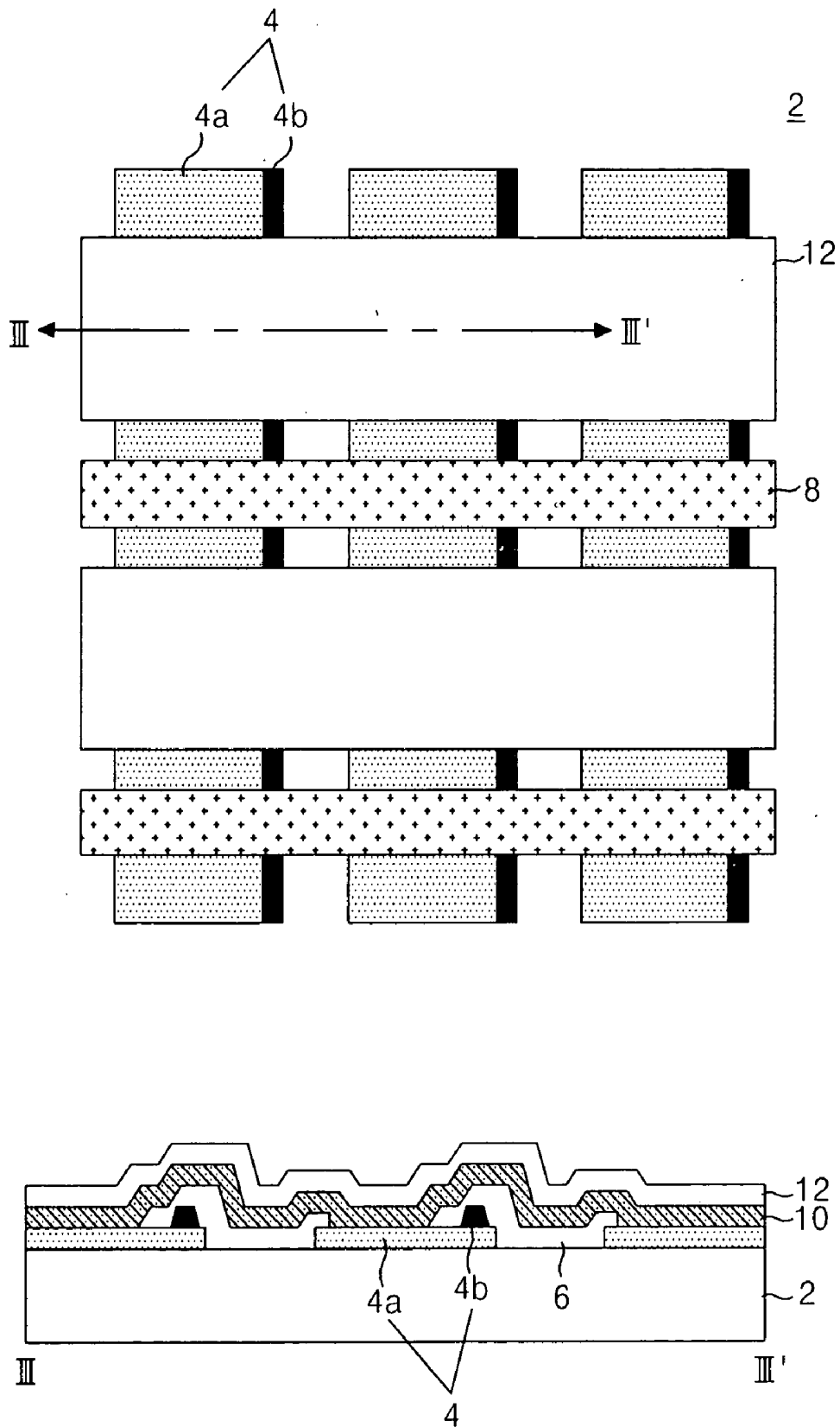
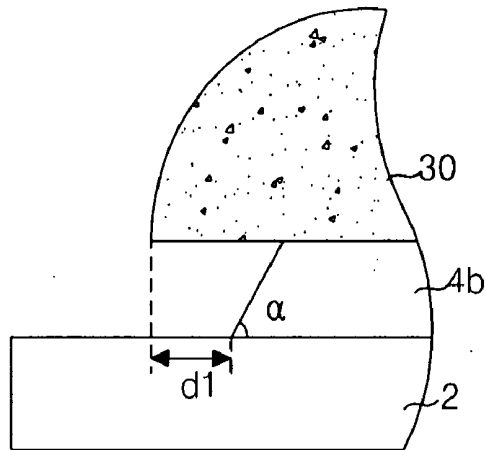
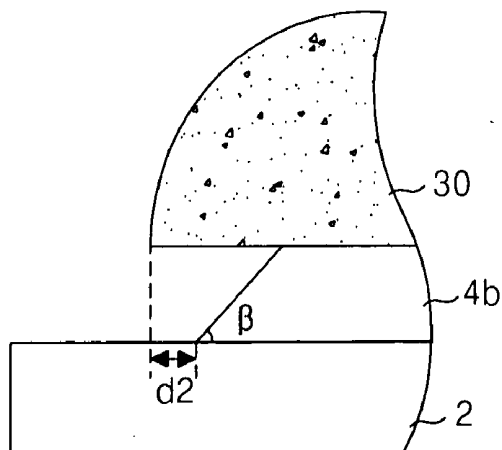

FIG. 7A



$$54^\circ \leq \alpha \leq 63^\circ$$

FIG. 7B



$$40^\circ \leq \beta \leq 49^\circ, d1 > d2$$

ORGANIC ELECTRO-LUMINESCENCE DISPLAY DEVICE AND METHOD OF FABRICATING THE SAME

[0001] This application claims the benefit of Korean Patent Application No. P2004-19684 filed in Korea on Mar. 23, 2004, which is hereby incorporated by reference.

BACKGROUND OF THE INVENTION

[0002] 1. Field of the Invention

[0003] This invention relates to an electro-luminescence display device, and more particularly, to an organic electro-luminescence display device and a method of fabricating the same that is capable of reducing an inverse taper of a bus electrode.

[0004] 2. Description of the Related Art

[0005] Recently, there have been developed various flat panel display devices reduced in weight and bulk that is capable of eliminating disadvantages of a cathode ray tube (CRT). Such flat panel display devices include a liquid crystal display (LCD), a field emission display (FED) device, a plasma display panel (PDP) and an electro-luminescence (EL) display device, etc. device. Especially, the EL display device has characteristics of a wide viewing angle, a high aperture rate and a high color purity, etc., such that it can be highlighted into a post-generation display device.

[0006] Such the EL display device comprises an anode electrode and a cathode electrode **12** with an organic layer therebetween, wherein the organic layer includes a hole carrier layer, a light-emitting layer, and an electron carrier layer. Electrons and holes emitted from these anode electrode and cathode electrode are re-combined with each other, thereby generating a visible light. At this time, the generated visible light is emitted, via the anode electrode, into an exterior to thereby display a predetermined picture or image.

[0007] Meanwhile, as shown in **FIG. 1**, an anode electrode **52** includes: a transparent **56** formed on a substrate **51**; and a bus electrode **54** formed on one side of the transparent electrode **56** to compensate a resistance component of the transparent electrode **56**.

[0008] Herein, the bus electrode **54** is formed by etching a chrome Cr, a molybdenum Mo, and a copper Cu, etc. using an etchant consisted of phosphoric acid in a range of 60 to 65 weight %, nitric acid in a range of 5 to 6 weight %, acetic acid of 10 weight %, and water in a range of 19 to 25 weight %. An inclination angle of the bus electrode **54** formed by using the etchant is relatively large as about 80° to 110°. Accordingly, a taper of the bus electrode **54** is deteriorated. In other words, the bus electrode **54** is formed in an inverse taper type in which the lower portion thereof has a narrower width than the upper portion thereof. An insulating film **58** formed to cover the anode electrode **52** having the bus electrode **54** makes a step coverage to be deteriorated, so that a pinhole A exposing the bus electrode **54** is occurred as shown in **FIG. 2**. An insulation breakdown is occurred by the pinhole, so that there is a problem that a reliance of the electro-luminescence display device is deteriorated, e.g., the anode electrode **52** and a cathode electrode are shorted.

SUMMARY OF THE INVENTION

[0009] Accordingly, it is an object of the present invention to provide an organic electro-luminescence display device

and a method of fabricating the same that is capable of reducing an inverse taper of a bus electrode.

[0010] In order to achieve these and other objects of the invention, an organic electro-luminescence display device comprises: an anode electrode including a transparent electrode and a bus electrode; a cathode electrode crossing the anode electrode; and an organic layer located at a cross both the anode electrode and the cathode electrode, wherein the bus electrode has an inclination angle of 30° to 70°.

[0011] The bus electrode has an inclination angle of 30° to 50°.

[0012] The anode electrode includes: the transparent electrode; and the bus electrode located on the transparent electrode.

[0013] The anode electrode includes: the bus electrode; and the transparent electrode located on the bus electrode.

[0014] In order to achieve these and other objects of the invention, a method of fabricating an organic electro-luminescence display device comprises: forming an anode electrode including a transparent electrode and a bus electrode on a substrate; forming an organic layer generating light on the substrate having the anode electrode; and forming a cathode electrode crossing the anode electrode on the substrate having the organic layer, wherein the bus electrode has an inclination angle of 30° to 70°.

[0015] The bus electrode has an inclination angle of 30° to 50°.

[0016] The forming the anode electrode having the transparent electrode and the bus electrode on the substrate includes: forming the transparent electrode on the substrate; and forming the bus electrode having the inclination angle of 30° to 70° on the transparent electrode.

[0017] The forming the anode electrode having the transparent electrode and the bus electrode on the substrate includes: forming the bus electrode having the inclination angle of 30° to 70° on the substrate; and forming the transparent electrode so as to contact with the bus electrode on the substrate having the bus electrode.

[0018] The forming the bus electrode having the inclination angle of 30° to 70° includes: depositing a metal on the substrate; and patterning the metal by a photolithography process and an etching process using an etchant to form the bus electrode.

[0019] The etchant is consisted of phosphoric acid in a range of 55 to 60 weight %, nitric acid in a range of 10 to 12 weight %, acetic acid in a range of 8 to 10 weight %, and water in a range of 18 to 27 weight %.

[0020] The etchant has a temperature of a normal temperature to 45° C.

[0021] The etchant has a temperature of 30° C. to 35° C.

[0022] The metal includes at least one of chrome, molybdenum, and copper.

BRIEF DESCRIPTION OF THE DRAWINGS

[0023] These and other objects of the invention will be apparent from the following detailed description of the

embodiments of the present invention with reference to the accompanying drawings, in which:

[0024] FIG. 1 is a perspective view illustrating an anode electrode of a related art organic electro-luminescence display device;

[0025] FIG. 2 is a sectional view illustrating a pinhole phenomenon of an insulating film by a bus electrode shown in FIG. 1;

[0026] FIG. 3 is a plan view illustrating an organic electro-luminescence display device according to the present invention;

[0027] FIG. 4 is a sectional view illustrating the organic electro-luminescence display device taken along a line II-II' in FIG. 3;

[0028] FIG. 5 is a sectional view illustrating the organic electro-luminescence display device taken along a line III-III' in FIG. 3;

[0029] FIGS. 6A to 6F are plan views and sectional views representing a method of manufacturing the organic electro-luminescence display device according to the present invention; and

[0030] FIGS. 7A and 7B are sectional views illustrating a taper angle of a bus electrode in accordance with a temperature of an etchant.

DETAILED DESCRIPTION OF THE PREFERRED EMBODIMENT

[0031] Reference will now be made in detail to the preferred embodiments of the present invention, examples of which are illustrated in the accompanying drawings.

[0032] Hereinafter, the preferred embodiments of the present invention will be described in detail with reference to FIGS. 3 to 7B.

[0033] FIG. 3 is a plan view illustrating an organic electro-luminescence display device according to the present invention, and FIG. 4 is a sectional view illustrating the organic electro-luminescence display device taken along a line II-II' in FIG. 3.

[0034] Referring to FIGS. 3 and 4, the related art electro-luminescence display device includes an insulating film 6, a barrier rib 8, and an organic layer 10 formed between, an anode electrode 4 and a cathode electrode 10, which are insulated from each other and crossing each other on a substrate 2.

[0035] A plurality of anode electrodes 4 is provided on the substrate 2 in such a manner to be spaced at a predetermined distance from each other. A first driving signal is supplied to such the anode electrode 4 in order to emit an electron(or hole).

[0036] As shown in FIG. 5, the anode electrode 4 includes: a transparent electrode 4a made of a transparent conductive material, e.g., indium-tin-oxide ITO, etc., on a substrate 2; and a bus electrode 4b made of chrome Cr, molybdenum Mo, copper Cu, and etc. on one side of the transparent electrode 4a to compensate a resistance component of the transparent electrode 4a. Furthermore, the anode electrode 4 may include: a bus electrode 4b formed on a

substrate 2; and a transparent electrode 4a formed on the substrate 2 having the bus electrode 4b.

[0037] Herein, the bus electrode 4b is formed to have a relatively smooth inclination angle of about 30° to 70°. Preferably, the bus electrode 4b is formed to have the inclination angle of about 30° to 50°

[0038] The insulating film 6 is formed in a lattice type so as to expose an aperture for each EL cell area on the substrate 2 having the anode electrode 4.

[0039] The barrier rib 8 is formed in a direction crossing the anode electrode 4, and is formed in parallel to the cathode electrode 12 by a predetermined distance to partition adjacent EL cells. In other words, the barrier rib 8 separates the organic layers 10 from each other and the cathode electrodes 12 from each other between the adjacent EL cells. Further, the barrier rib 8 has an overhang structure in which the upper portion thereof has a larger width than the lower portion thereof.

[0040] The organic layer 10 is made of an organic compound on the insulating film 6. In other words, the organic layer 10 is formed by depositing a hole carrier layer, a light-emitting layer and an electron carrier layer onto the insulating film 6.

[0041] A plurality of cathode electrodes 12 is provided on the organic layer 10 in such a manner to be spaced at a predetermined distance from each other, and in such a manner to be crossed with the anode electrodes 4. A second driving signal is supplied to the cathode electrode 12 in order to emit a hole(or electron).

[0042] As set forth above, in the organic electro-luminescence display device according to the present, the bus electrode 4b is formed to have an inclination angle of 30° to 70°. Accordingly, a taper of the bus electrode 4b having a relatively smooth inclination angle becomes improved, so that a step coverage of the insulating film 6 formed to cover the bus electrode 4b becomes improved. Thus, it is possible to prevent an insulation breakdown.

[0043] FIGS. 6A to 6F are plan views and sectional views representing a method of manufacturing the organic electro-luminescence display device according to the present invention.

[0044] Firstly, a transparent conductive material, e.g., indium-tin-oxide, etc., is deposited and then patterned on a substrate 2, to thereby form a transparent electrode 4a of an anode electrode on the substrate as shown in FIG. 6.

[0045] Chrome Cr or Molybdenum Mo, etc. is deposited on the substrate 2 having the transparent electrode 4a and then is patterned by a photolithography process and an etching process using an etchant consisted of phosphoric acid in a range of 55 to 60 weight %, nitric acid in a range of 10 to 12 weight %, acetic acid in a range of 8 to 10 weight %, and water in a range of 18 to 27 weight %, to thereby form a bus electrode 4b of an anode electrode having a taper angle of 30° to 70° as shown in FIG. 6B. The etching process of the bus electrode 4b will be described in detail later.

[0046] A photosensitive insulating material is deposited and then patterned on the substrate 2 having the anode electrode 4, to thereby form a insulating film 6 as shown in

FIG. 6C. The insulating film **6** is formed in a lattice type at an entire portion except for a light-emitting portion.

[0047] A photosensitive insulating material is deposited and then patterned on the substrate **2** having the insulating film **6**, to thereby form a barrier rib **8** as shown in **FIG. 6D**. The barrier rib **8** is formed with a predetermined distance from adjacent barrier ribs in a direction crossing the anode electrode **4**, and is formed at a non-light emitting portion.

[0048] An organic layer **10** is formed on the substrate having the barrier rib **8** as shown in **FIG. 6E**. The organic layer **10** includes hole carrier layer, a light emitting layer, and an electron carrier layer.

[0049] A cathode electrode **12** is formed on the substrate **2** having the organic layer **10** as shown in **FIG. 6F**. At this time, the cathode electrode **12** is entirely deposited to be formed, but is separated for each EL cell by the barrier rib having a relatively high height to be formed.

[0050] Meanwhile, the bus electrode **4b** of the anode electrode according to the present invention is formed with result that a metal such as chrome Cr, molybdenum Mo, copper Cu, etc. is etched by an anisotropic etching manner using an etchant consisted of compositions shown in table 1, at a temperature of a normal temperature to 45° C., preferably temperature of about 30° C. to 35° C. The bus electrode **4b** formed by the etching manner using the etchant has an inclination angle of 30° to 70°.

TABLE 1

	Phosphoric acid	Nitric acid	Acetic acid	Water
Composition content (weight %)	55 to 60	10 to 12	8 to 10	18 to 28

[0051] As shown in Table 1, a content of nitric acid becomes larger by about double amount than that of the related art, so that an etching speed of a metal making the bus electrode **4b** becomes slower. Accordingly, the bus electrode **4b** can be formed with an inclination angle smaller than that of the related art.

[0052] Meanwhile, an etching amount and inclination angle of the bus electrode **4b** formed by the etchant shown in Table 1 are differentiated depending upon a temperature of the etchant as shown in Table 2.

TABLE 2

Temperature of etchant (° C.)	first location	second location	third location	Inclination angle of bus electrode
30° C.	0.20 μm	0.21 μm	0.28 μm	40° C. to 49° C.
40° C.	0.54 μm	0.44 μm	0.52 μm	54° C. to 63° C.

[0053] In a case that a temperature of the etchant is 40° C., the bus electrode **4b** located at a first location(near upper corner of right side in the substrate) is etched by about 0.54 μm from end of a photo-resist pattern **30** formed by an etching process and a developing process as shown in **FIG. 7A**, the bus electrode **4b** located at a second location(near center of the substrate) is etched by about 0.44 μm from end

of the photo-resist pattern **30**, and the bus electrode **4b** located at a third location(near lower corner of left side of the substrate) is etched by about 0.52 μm from end of the photo-resist pattern **30**. As set forth above, when the temperature of the etchant is 40° C., the bus electrode **4b** is over-etched by a first width d1 from end of the photo-resist pattern **30** and the bus electrode **4b** has a inclination angle α of about 54° to 63°.

[0054] On the other hand, in a case that a temperature of the etchant is 30° C., the bus electrode **4b** located at a first location(near upper corner of right side in the substrate) is etched by about 0.20 μm from end of a photo-resist pattern **30** formed by an etching process and a developing process as shown in **FIG. 7B**, the bus electrode **4b** located at a second location(near center of the substrate) is etched by about 0.21 μm from end of the photo-resist pattern **30**, and the bus electrode **4b** located at a third location(near lower corner of left side of the substrate) is etched by about 0.28 μm from end of the photo-resist pattern **30**. As set forth above, when the temperature of the etchant is 30° C., the bus electrode **4b** is over-etched by a second width shorter than the first width d1, from end of the photo-resist pattern **30**, and the bus electrode **4b** has a inclination angle β of about 40° to 49°.

[0055] As set forth above, when the temperature of the etchant is 30° C. as compared with 40° C., an over-etched amount of the bus electrode **4b** is a relatively small and inclination angle of the bus electrode **4b** becomes relatively smaller.

[0056] As described above, in the organic electro-luminescence display device and the method of fabricating the same according to the present invention, the bus electrode is formed to have the inclination angle of 30° to 70°. Accordingly, the taper of the bus electrode having a relatively smooth inclination angle becomes improved, so that a step coverage of the insulating film formed to cover the bus electrode becomes improved. Thus, it is possible to prevent an insulation breakdown.

[0057] Although the present invention has been explained by the embodiments shown in the drawings described above, it should be understood to the ordinary skilled person in the art that the invention is not limited to the embodiments, but rather that various changes or modifications thereof are possible without departing from the spirit of the invention. Accordingly, the scope of the invention shall be determined only by the appended claims and their equivalents.

What is claimed is:

1. An organic electro-luminescence display device comprising:

an anode electrode including a transparent electrode and a bus electrode;

a cathode electrode crossing the anode electrode; and

an organic layer located at a cross both the anode electrode and the cathode electrode,

wherein the bus electrode has an inclination angle of 30° to 70°.

2. The device according to claim 1, wherein the bus electrode has an inclination angle of 30° to 50°.

3. The device according to claim 1, wherein the anode electrode includes:

the transparent electrode; and
the bus electrode located on the transparent electrode.

4. The device according to claim 1, wherein the anode electrode includes:
the bus electrode; and
the transparent electrode located on the bus electrode.

5. A method of fabricating an organic electro-luminescence display device comprising:
forming an anode electrode including a transparent electrode and a bus electrode on a substrate;
forming an organic layer generating light on the substrate having the anode electrode; and
forming a cathode electrode crossing the anode electrode on the substrate having the organic layer,
wherein the bus electrode has an inclination angle of 30° to 70°.

6. The method according to claim 5, wherein the bus electrode has an inclination angle of 30° to 50°.

7. The method according to claim 5, wherein the forming the anode electrode having the transparent electrode and the bus electrode on the substrate includes:
forming the transparent electrode on the substrate; and
forming the bus electrode having the inclination angle of 30° to 70° on the transparent electrode.

8. The method according to claim 5, wherein the forming the anode electrode having the transparent electrode and the bus electrode on the substrate includes:

forming the bus electrode having the inclination angle of 30° to 70° on the substrate; and

forming the transparent electrode so as to contact with the bus electrode on the substrate having the bus electrode.

9. The method according to any one of claim 7 and claim 8, wherein the forming the bus electrode having the inclination angle of 30° to 70° includes:

depositing a metal on the substrate; and

patterning the metal by a photolithography process and an etching process using an etchant to form the bus electrode.

10. The method according to claim 9, wherein the etchant is consisted of phosphoric acid in a range of 55 to 60 weight %, nitric acid in a range of 10 to 12 weight %, acetic acid in a range of 8 to 10 weight %, and water in a range of 18 to 27 weight %.

11. The method according to claim 9, wherein the etchant has a temperature of a normal temperature to 45° C.

12. The method according to claim 11, wherein the etchant has a temperature of 30° C. to 35° C.

13. The method according to claim 9, wherein the metal includes at least one of chrome, molybdenum, and copper.

* * * * *

专利名称(译)	有机电致发光显示装置及其制造方法		
公开(公告)号	US20050212415A1	公开(公告)日	2005-09-29
申请号	US11/084791	申请日	2005-03-21
申请(专利权)人(译)	LG电子株式会社.		
当前申请(专利权)人(译)	LG电子株式会社.		
[标]发明人	JUNG YOUNG RO JU JAE HYOUNG		
发明人	JUNG, YOUNG RO JU, JAE HYOUNG		
IPC分类号	H05B33/26 H01L27/32 H01L51/50 H01L51/52 H01L51/56 H05B33/10 H05B33/00 H01J1/62 H01J63/04		
CPC分类号	H01L27/3281 H01L51/5212 H01L51/5206		
优先权	1020040019684 2004-03-23 KR		
其他公开文献	US7825593		
外部链接	Espacenet USPTO		

摘要(译)

有机电致发光器件及其制造方法本发明涉及一种能够减小母线电极的倒锥形的有机电致发光器件及其制造方法。一种有机电致发光显示装置，包括：阳极，包括透明电极和汇流电极；阴极电极与阳极电极交叉；和位于阳极和阴极交叉处的有机层，其中汇流电极具有30°至70°的倾斜角。

